



TBLC

Non-marking vertical lifting of materials with parallel sides without minimum WLL

Application:

- For vertical lifting and transporting of all plates, blocks and structures with parallel sides without marking, scratching and or damaging the material surface
- Perfect for lifting materials such as (stainless) steel, aluminum, nature stone, composite, painted materials, wood, glass, plastic, etc.
- The clamp is locked in the open position. To lift, the operator must activate the handle and hold it up while the lifting eye moves up. This will result in the clamp closing. When Laying down the load, the clamp automatically locks itself open
- Jaw openings available from: 30 to 500 mm
- Working load limit (WLL) 500 - 3000 kg.
- No min. WLL



Features and Benefits:

- 2 special synthetic anti-friction pads to guarantee non-marking
- Lightweight design and easy to use
- Tough quality heavy duty body
- Maintenance-friendly, easy to exchange parts which are available upon request

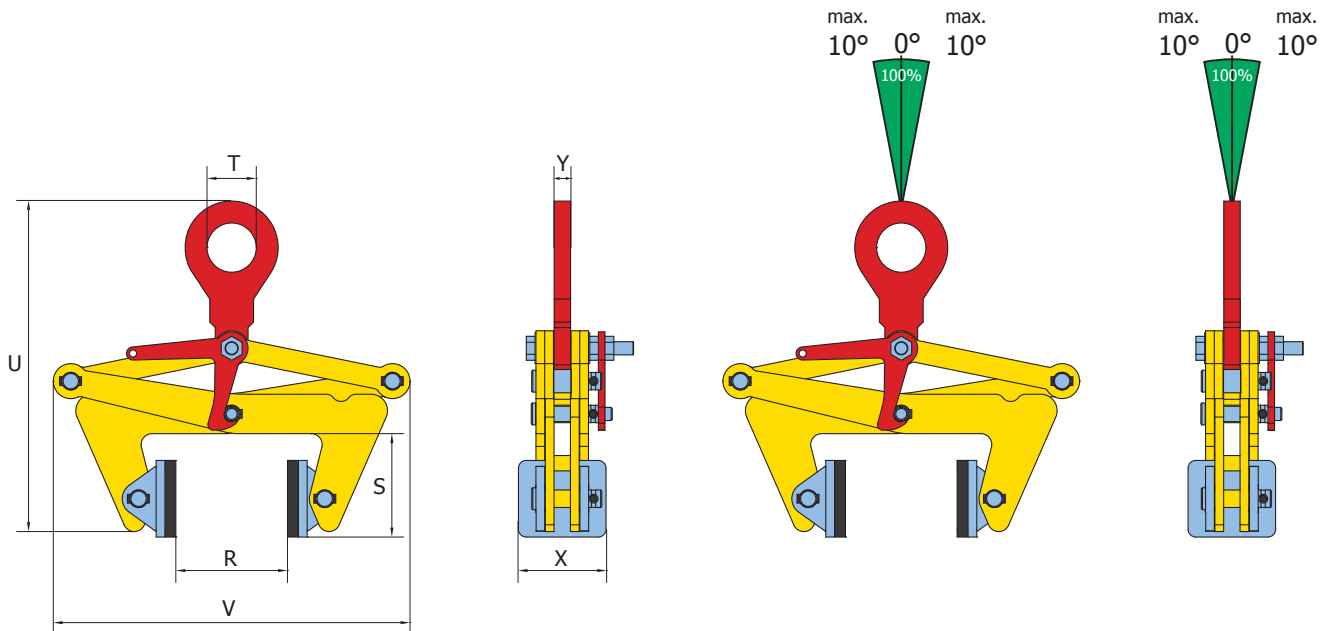

Article Nr.	Type	Capacity (kg/pc)	Jaw opening (R) (mm)	Dimensions in mm						Weight (kg/pc)
				V min-max	U min-max	S	T	X	Y	
801005	0.5 TBLC	500	30 - 110	270-325	305-460	95	45	80 (*70)	15	7
801010	1 TBLC	1000	100 - 230	425-530	380 -655	120	45	80 (*70)	15	12,3
801020	2 TBLC	2000	220 - 360	580 -675	410-735	140	45	80 (*70)	15	18
801030	3 TBLC	3000	350 - 500	725-835	530-900	178	64	100 (*90)	16	33