



# DIN 05L

*Electronic Dynamometer*

Complete group made of load cell and electronic weight indicator. Designed to weigh suspended loads.

## TECHNICAL CHARACTERISTICS

## DIMENSIONS mm

### Construction: Aluminium

**Load cell safe load limit:** 200% of nominal capacity

**Breaking load coefficient:** > 5

**Protection:** IP65 (EN 60529)

**Working temperature:** -5°C ÷ +55°C

**Accuracy:** ± 0,1% of the nominal load

**Power supply:** n°3 battery Type "AA" (battery life 180h)

**Display indications:** 5 digits, stable weight, battery life, measuring unit

### Features:

- Digital zero and weight settings;
- Digital filter selection (greater attenuation of weight oscillations)
- Automatic power-off selection
- Peak function and Hold function
- Measuring units selection (kg – N – kN - lb)

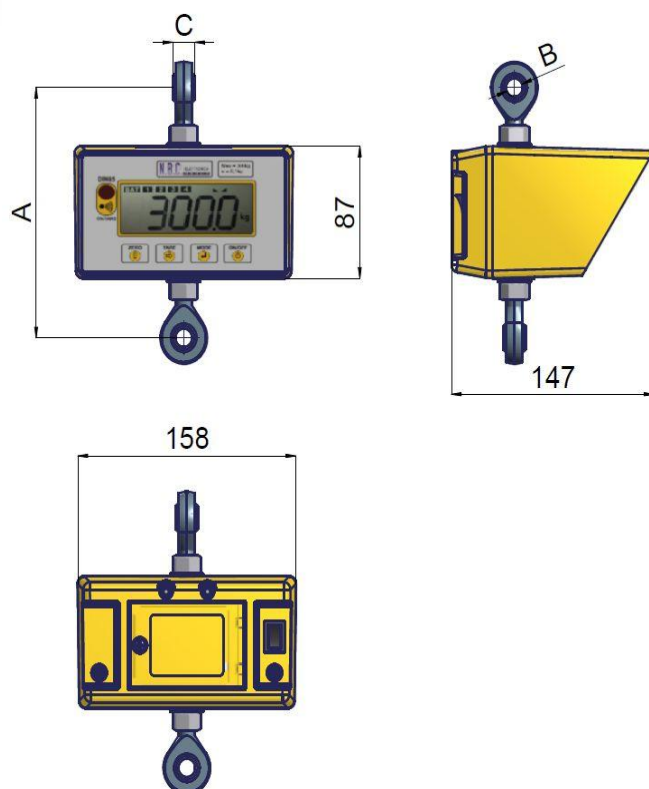

Portata	Divisione	Dimensioni (mm)			Peso
Capacity	Readability	A	B	C	Weight
50 kg	0,02 kg	158	12	16	1,3 kg
100 kg	0,05 kg	158	12	16	1,3 kg
300 kg	0,1 kg	158	12	16	1,3 kg
600 kg	0,2 kg	170	16	21	2,3 kg
1000 kg	0,5 kg	170	16	21	2,3 kg

### OPTIONAL:

Telecomando ad infrarossi per accensione ed azzeramento tara /  
Infrared remote control for power-on and tare zeroing