



Hand Winches Model No. HW



General Purpose Hand Winch HW-2000 (can be ceiling mounted)

- 2000lb/900kg capacity
- Available in regular or split reel, which allows for operation of two line or cables for greater versatility
- Available in handle or loop drive models
- Can be ceiling mounted with loop drive
- Operating temperature -20°C to +80°C (temperature range of -40°C to +80°C available as an option)

Some of the HW-2000 stock precedes the enhancements with the additional gear cover. Please contact us for details.



General Purpose Hand Winch HW-1200

- 1200lb/545kg capacity
- Ability to disengage the gear to allow fast pay out of the cable

General Purpose Hand Winch HW-0600

- 600lb/270kg capacity
- Ability to disengage the gear to allow fast pay out of the cable

Certification:

Each unit comes fully certified with a test certificate or an EC Declaration of Conformity stating compliance with the essential health and safety requirements of the Machinery Directive 2006/42/EC.

Technical Data

Product Code	Pulling Capacity (lbs/kg)	Hand Force Required (kg)	Gear Ratio	Hub Diameter (mm)	Handle Length (mm)	Unit Weight (with handle) (kg)	Unit Weight (with loop) (kg)	Cable Diameter (mm/inch)	Cable Storage Cap. (m)
HW-0600	600/270	7.0	3.1:1	ø19	175	*2.26	--	ø4.0/ø5/32	28
HW-1200	1200/545	20.0	4.1:1	ø50	210	*2.84	--	ø4.8/ø3/16	29
HW-2000	2000/900	4.5	41:1	ø48	195	*5.1	*4.8	ø5.6/ø7/32	11*2



Technical Drawings

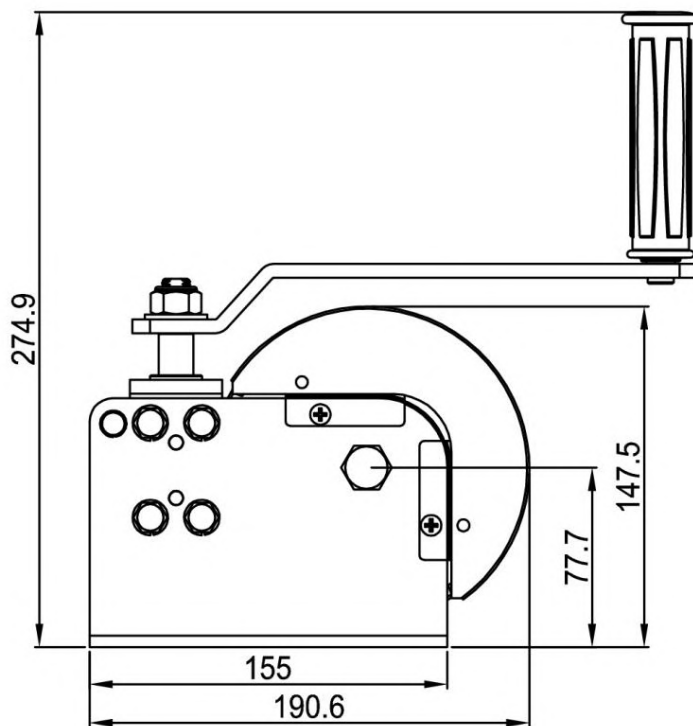
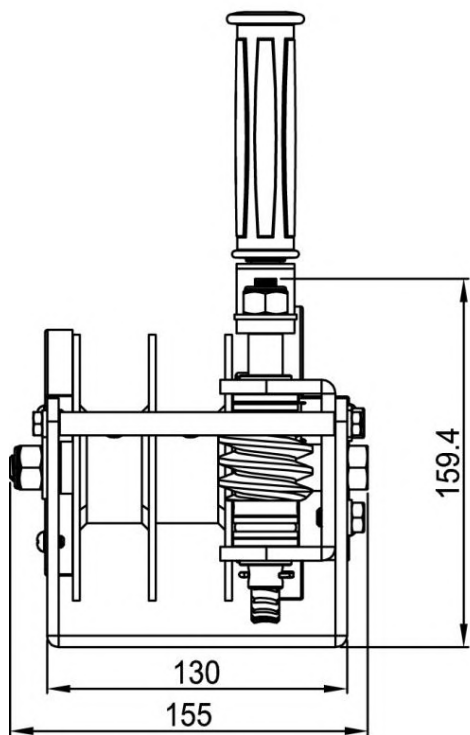
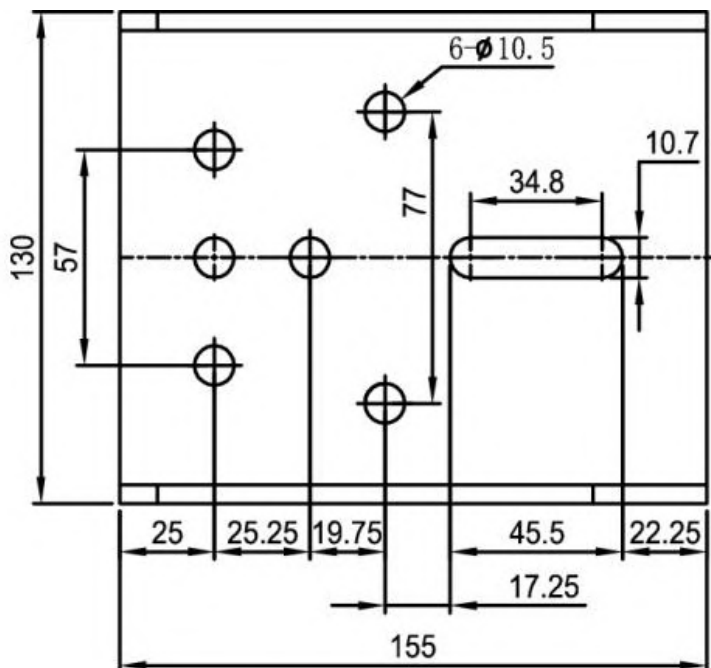

HW-2000 (with handle)

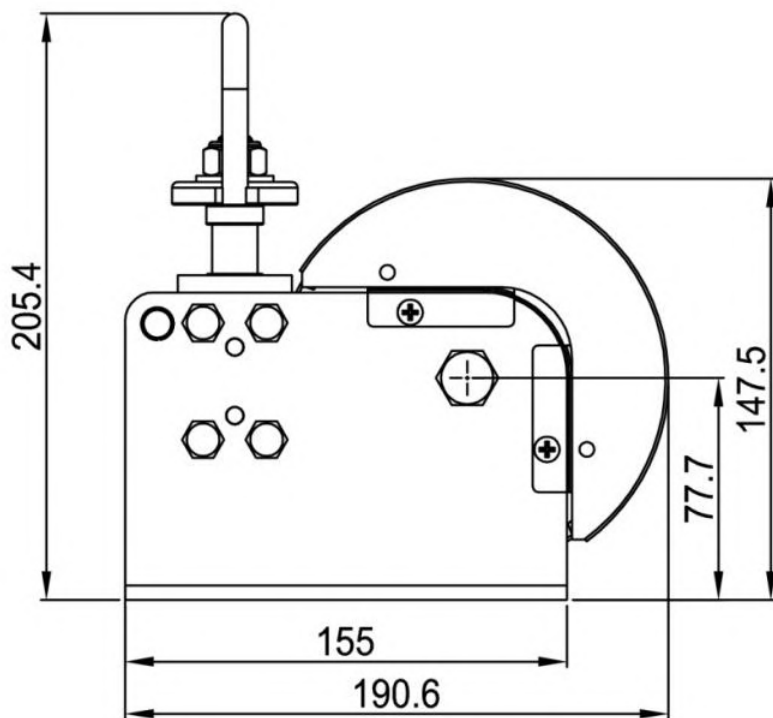
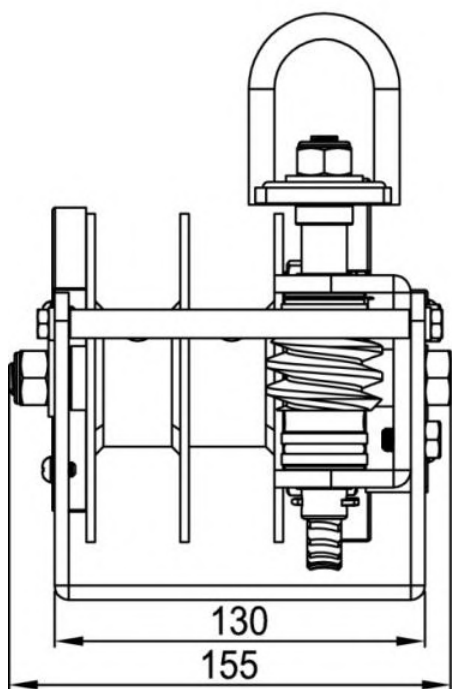
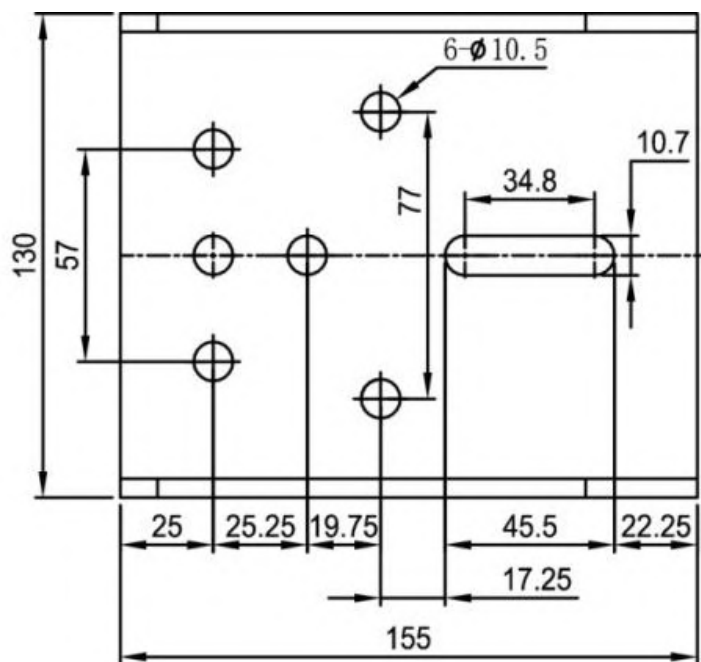

HW-2000 (with loop)

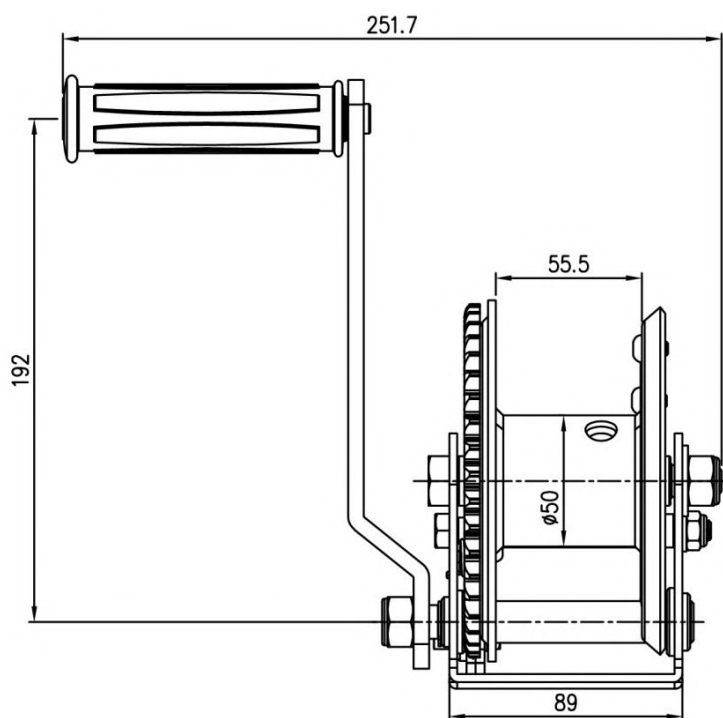
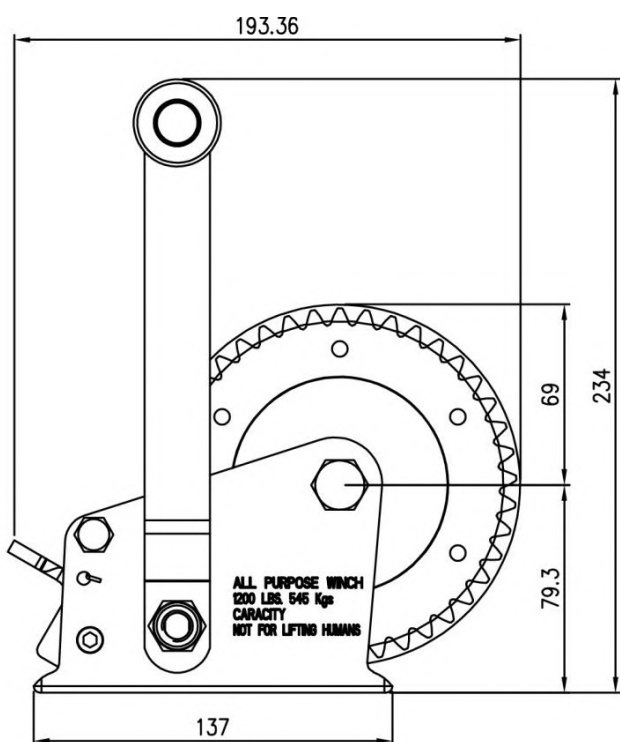
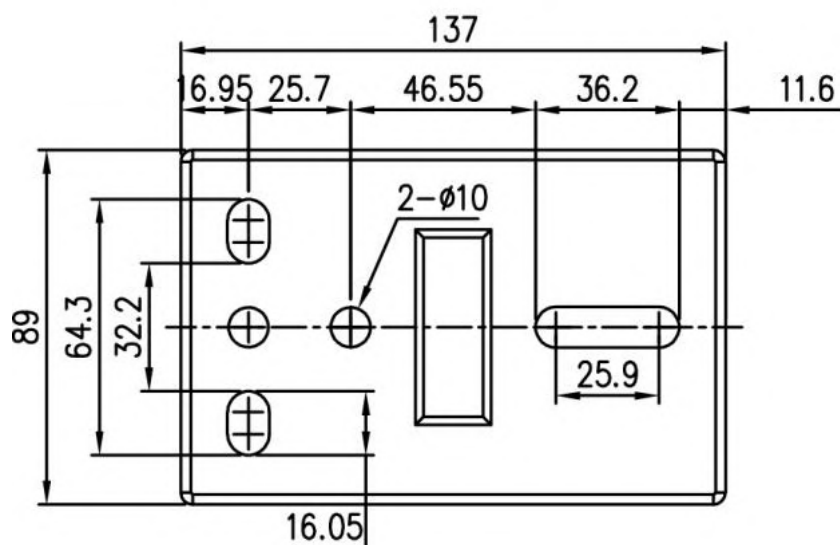

HW-1200

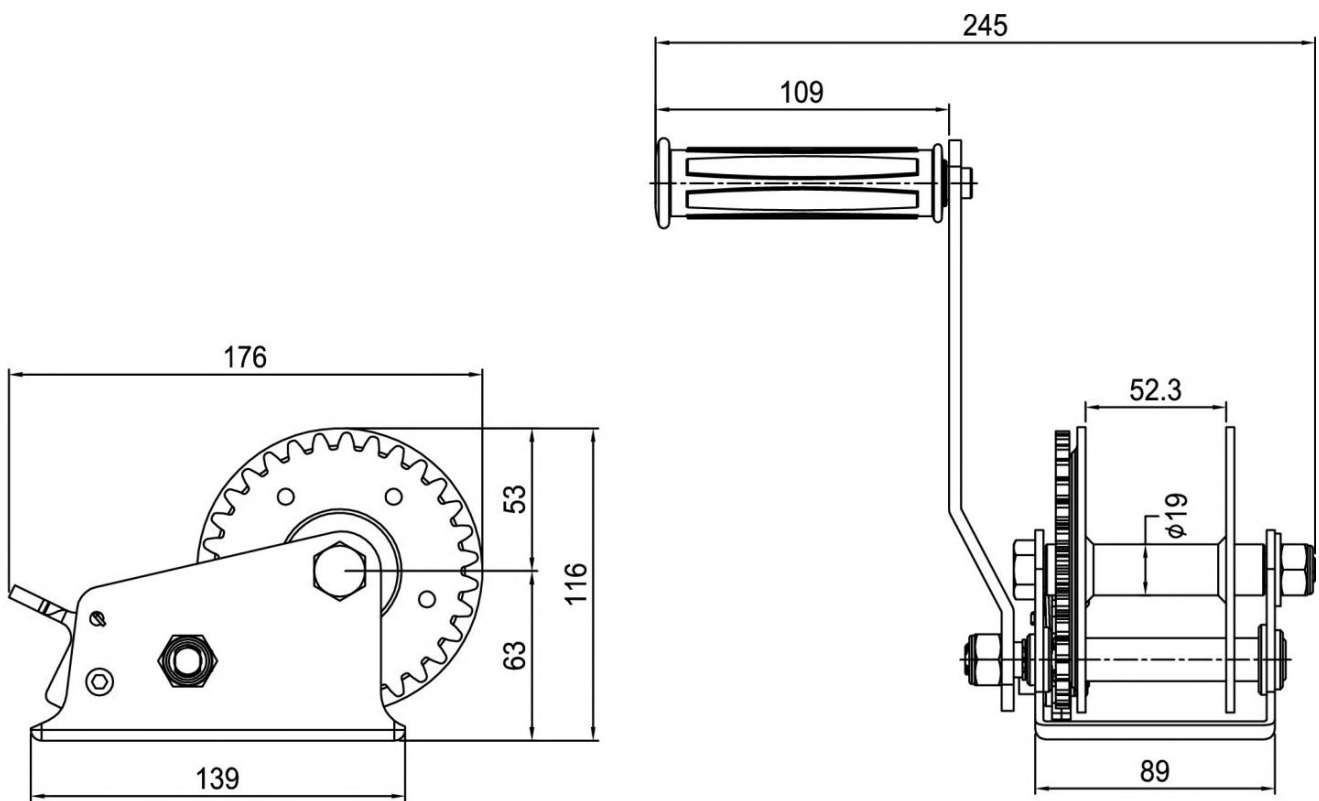
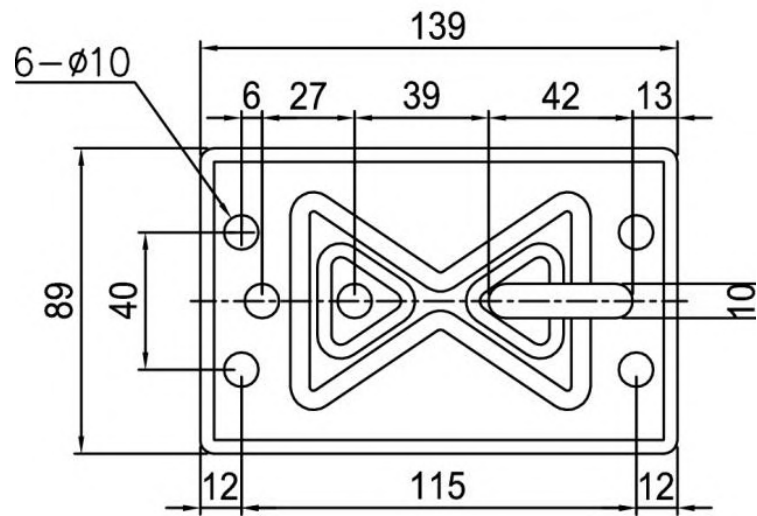

HW-0600